



RL Europe

Your partner in LED



Technical Application Guide for RL EUROPE LED Ceiling light

RL-AL24A-16-35W

Introduction

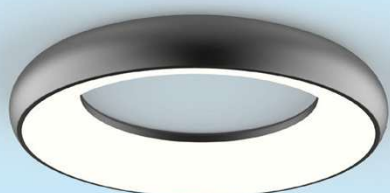

The hollow shape is full of creativity which brings vitality into ordinary lamp body and shows faultless performance, provides a strong sense of space.

The curved light direction emphasizes target object in a smooth and dramatic atmosphere, revealing an unexpected art inspiration design, which brings a comfortable way of visual experience.

By having an arc luminous surface, we break traditional design. The circular light output offers a magic 3D effect; rotate buckle on the base to make installation easier and faster.

- Up to 70% energy saving compared to standard CFL
- Long lifetime of 40,000 hours
- Triac dim
- 120° wide beam angle
- CCT: 3000K 4000K
5000K 5700K
- No UV/IR light
- Environment friendly, without Mercury or any other hazardous substances

Application notes

- IP40 for indoor use only
- Professional electrician for installation only
- Switch off before installation
- Do not touch when in use
- Keep away from hot steam and corrosive gas

Application Areas

Suitable for leisure location, such as: home, hotel, library, restaurant, cafe shop etc.

Certificate



Product Information

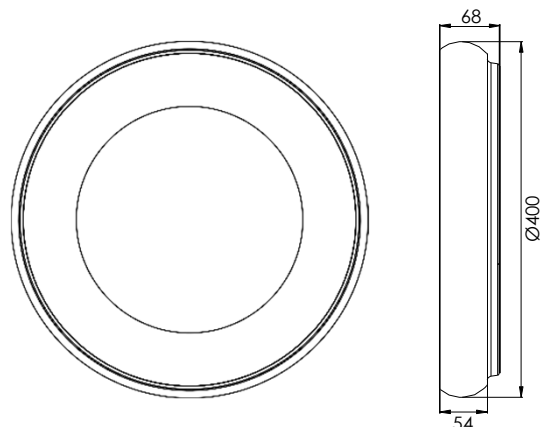

Technical Specifications

Model	Voltage	Power	Power Factor	Lumen (±5%)	Beam angle	CCT	Lifespan	CRI	Dimmable	Dimension
RL-AL24A-16-35W	AC100-240V	35W	≥0.9	2800	120°	3000K	40000h	≥80	No	Ø400*68mm
RL-AL24A-16-35W	AC100-240V	35W	≥0.9	3000	120°	4000K	40000h	≥80	No	Ø400*68mm
RL-AL24A-16-35W	AC100-240V	35W	≥0.9	3050	120°	5000K	40000h	≥80	No	Ø400*68mm
RL-AL24A-16-35W	AC100-240V	35W	≥0.9	3100	120°	5700K	40000h	≥80	No	Ø400*68mm
RL-AL24A-16-35W-D	AC230V	35W	≥0.9	2700	120°	3000K	40000h	≥80	Yes	Ø400*68mm
RL-AL24A-16-35W-D	AC230V	35W	≥0.9	2860	120°	4000K	40000h	≥80	Yes	Ø400*68mm
RL-AL24A-16-35W-D	AC230V	35W	≥0.9	2910	120°	5000K	40000h	≥80	Yes	Ø400*68mm
RL-AL24A-16-35W-D	AC230V	35W	≥0.9	2960	120°	5700K	40000h	≥80	Yes	Ø400*68mm

Driver data Sheet

Driver data	DIM	Non dim
Input rated Voltage	AC230V	AC100-240V
Frequency	50Hz	50/60Hz
Input Voltage	AC200-240V	AC85-265V
Efficiency	≥85%	≥88%
Total load Wattage	35W±5%	35W±5%
Power Factor	≥0.9	≥0.9
Rated input current	≤0.2A	≤0.46A
Full load output Voltage	DC65-75V	DC65-75V
Rated output current	430mA	440mA
Output current range	430mA±5%	440mA±5%
Power tolerance	±5%	±5%
Current output tolerance	±5%	±5%
Dimming range	8%-100%	—
Dimmer	Triac dimmers	—
Short circuit protection	PASS	PASS
Over voltage protection	PASS	PASS
Over temperature protection	PASS	PASS
THD	≤20%	≤20%
Withstand voltage	—	—

Fixture Compatibility

Rated Wattage	Electrical Classification	Ingress Protection	Operating Temp	Operating Humidity	Storage Temp
35W	I	IP40	-20°C~45°C	0~90%	-20°C~65°C

Spectral Distribution

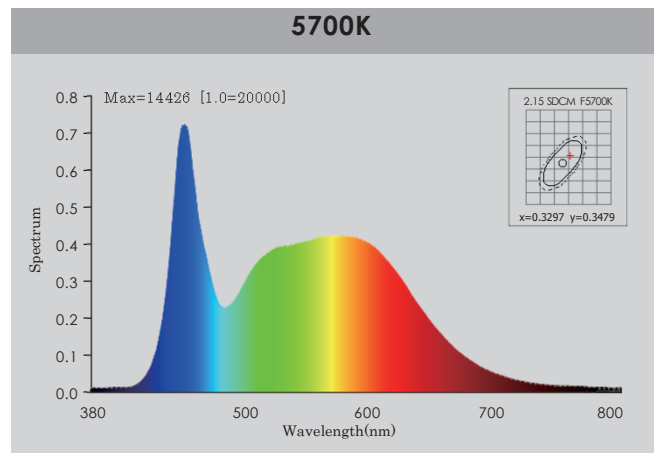
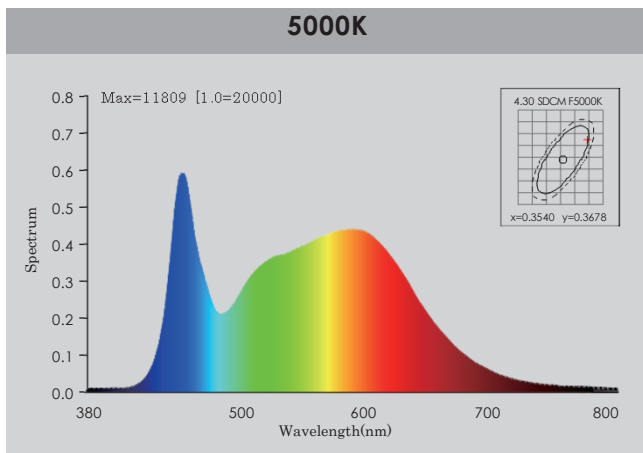
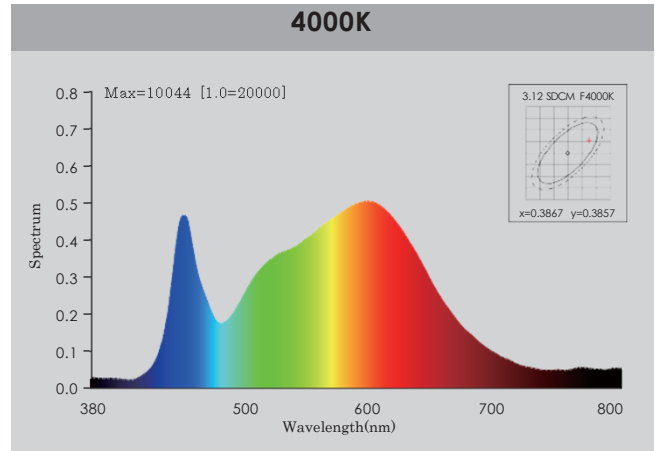
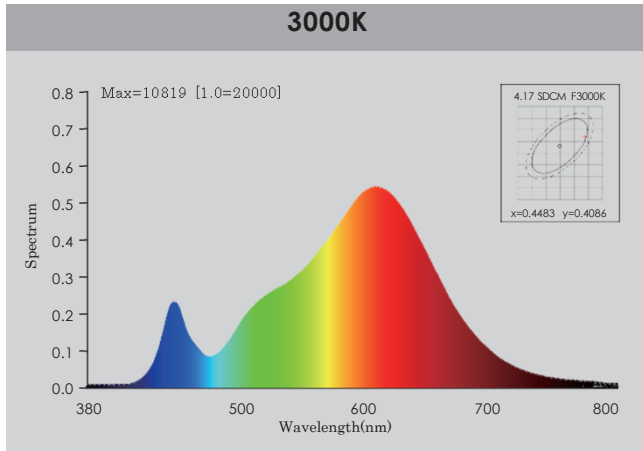

Photometric Diagram

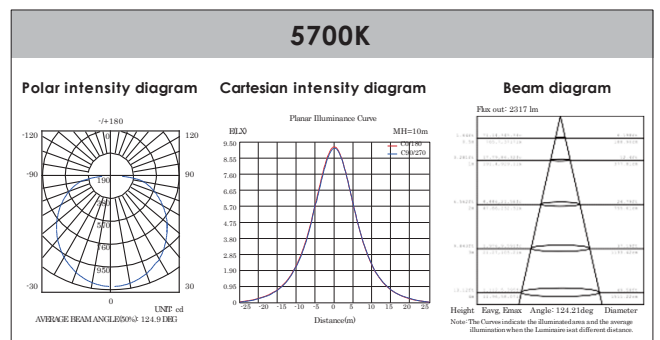
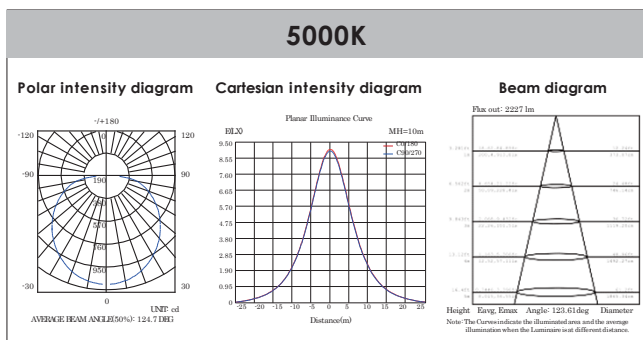
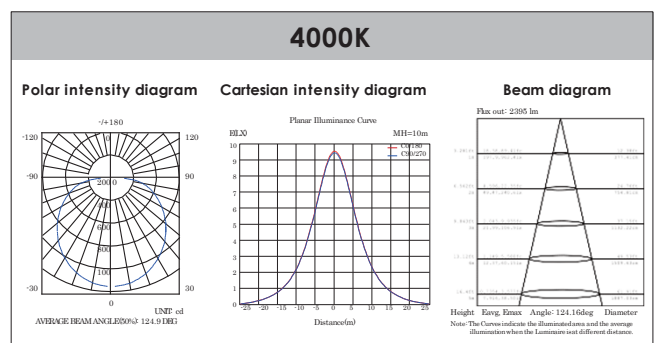
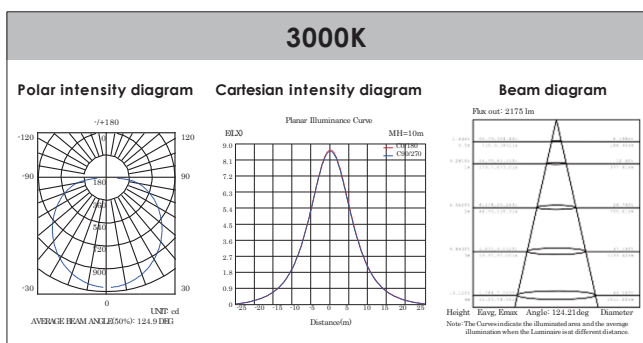

Polar Diagram Comparison

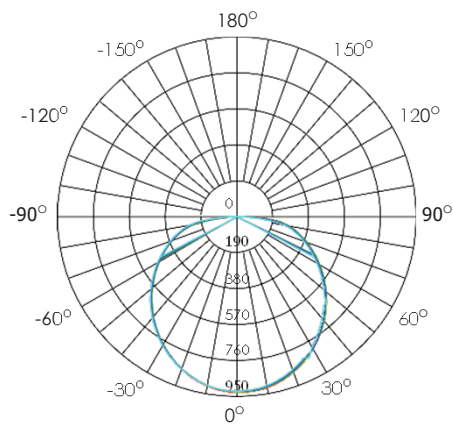

UNIT: cd

- C0/180, 124.9 deg
- C30/210, 124.8 deg
- C60/240, 124.9 deg
- C90/270, 124.8 deg



AVERAGE BEAM ANGLE (50%): 124.9DEG

Driver lifetime & LED light decay rate

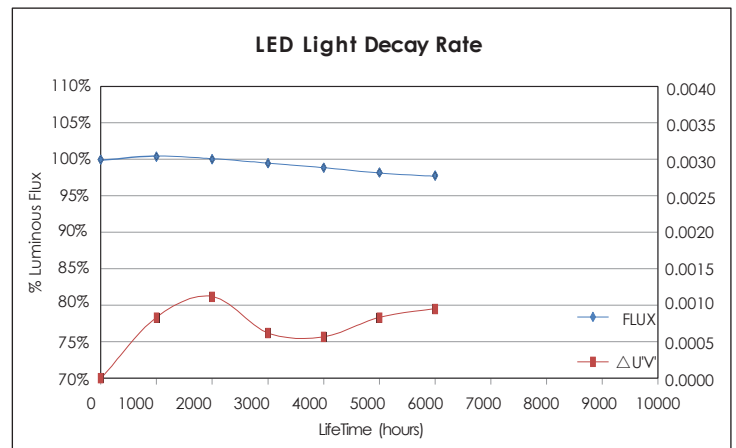
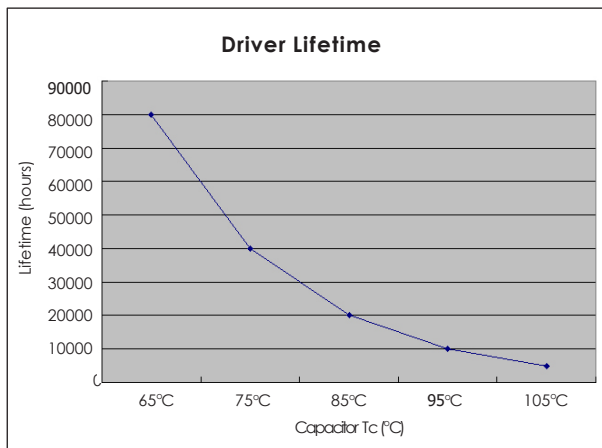

Temperature

- The testing is operated at 25°C
- The lifetime of capacitor, minimum of 5,000 hours if operated at 105°C, will be doubled whenever the temperature drops 10°C
- The highest withstand temperature of IC, MOS could be 120°C
- The highest withstand temperature of LED junction temperature is 150°C

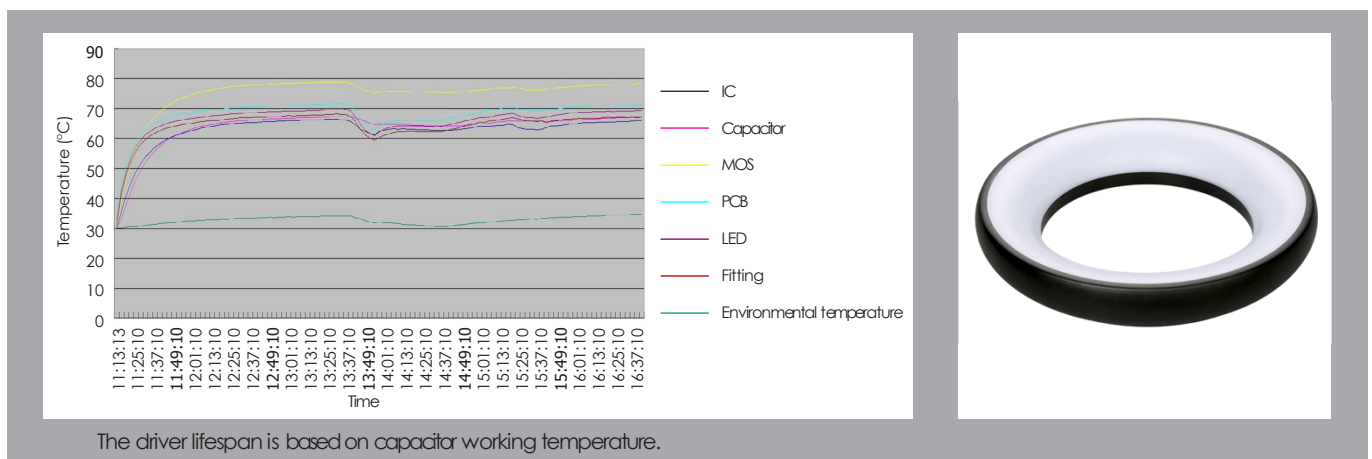

The driver lifespan is based on capacitor working temperature.



Installation

Surface mounted (Ring version)

<p>1</p> <p>Ring version</p> <p>accessory pack</p>	<p>2</p> <p>Punch the plastic anchor into ceiling.</p> <p>Fix bracket onto ceiling with screws.</p>
<p>3</p> <p>Wiring the input AC cable to the lamp</p> <p>L = BROWN N = BLUE = YELLOW-GREEN</p>	<p>4</p> <p>Fix the luminaire to the bracket, the slots should be firmly attached to the hooks of the bracket.</p> <p>slot</p> <p>15°</p>
<p>5</p> <p>Installation complete, switch on.</p>	

Surface mounted (Disc version)

<p>1</p> <p>Disc version</p> <p>accessory pack</p>	<p>2</p> <p>Punch the plastic anchor into ceiling.</p> <p>Fix bracket onto ceiling with screws.</p>
--	---

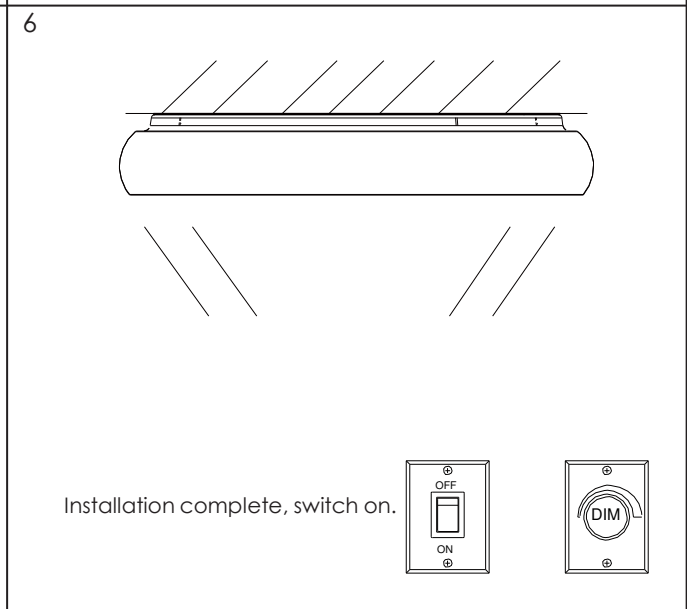
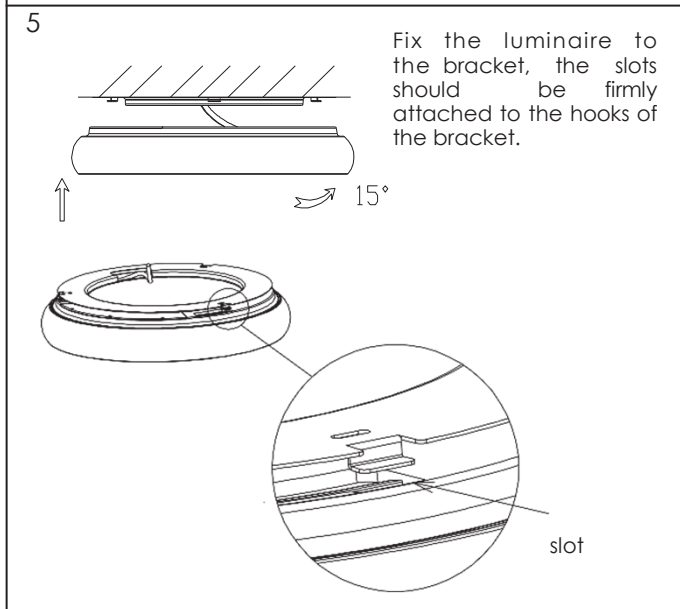
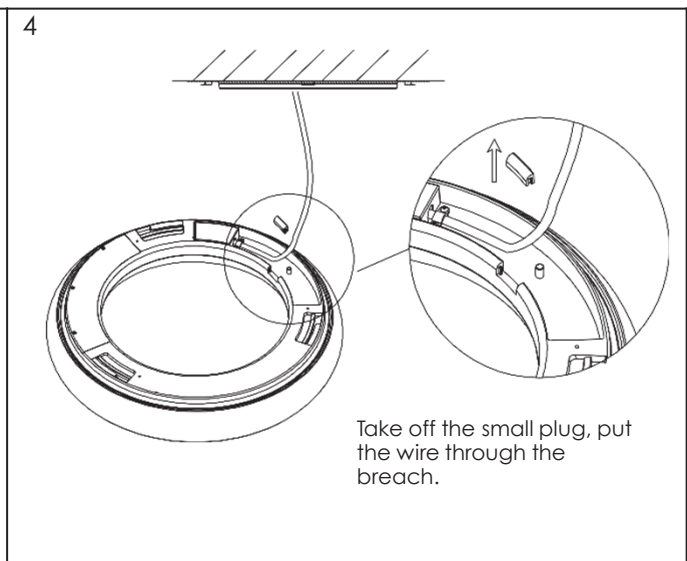
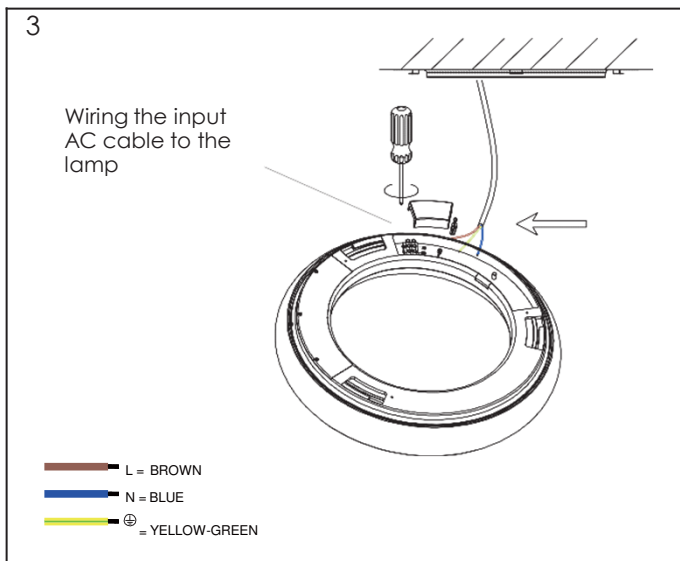

Suspended Installation

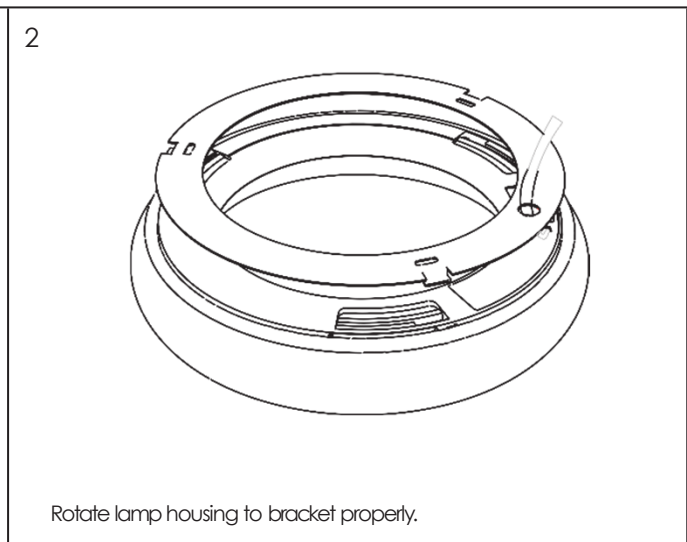
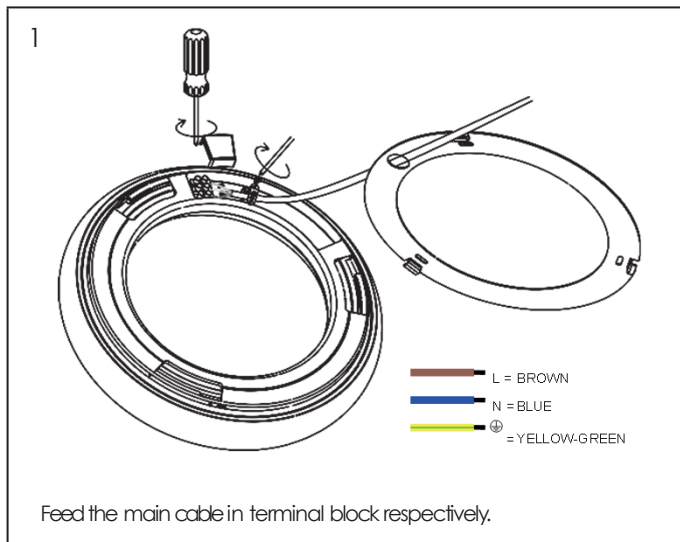

3

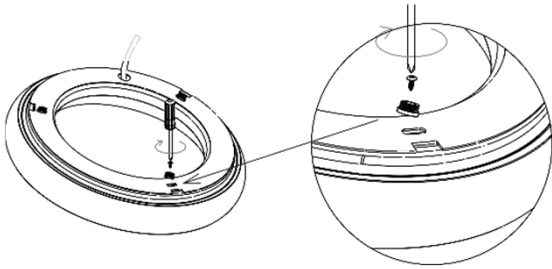

Fix three pieces of bases on surface mounted bracket.

1. Attach transparent DC wire to suspending rope by clips;
2. Fix the suspending ropes on the bases.

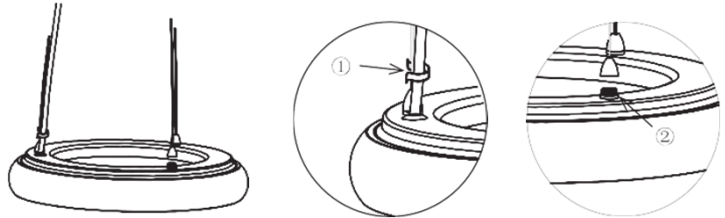

4

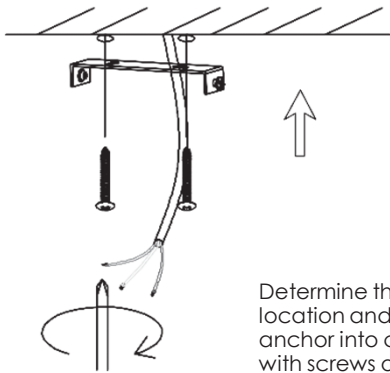

Determine the mounting location and knock the plastic anchor into ceiling, fix bracket with screws onto the ceiling.

5

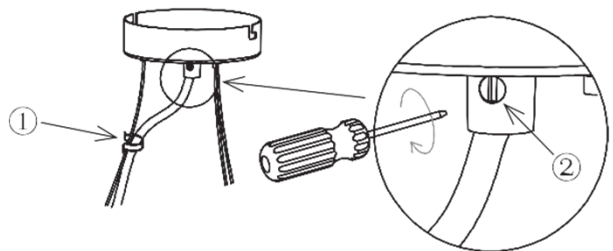

1. Insert the transparent cable through cable entry;
2. Tighten screw by screwdriver to fix the cable.

6

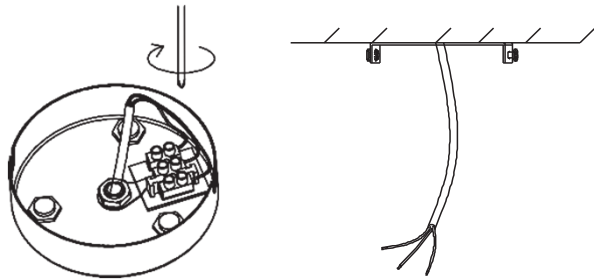

Feed the main cable in terminal block respectively.

— L = BROWN
— N = BLUE
— PE = YELLOW-GREEN

7

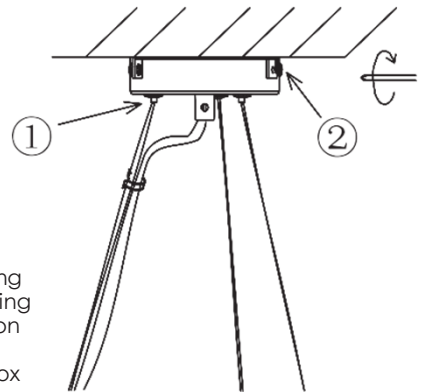

1. Adjust the suspending wire length by pressing the locking device on surface mount box,
2. Fix surface mount box onto bracket with screw.

Finish

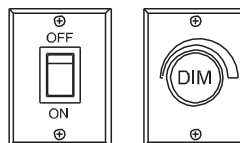
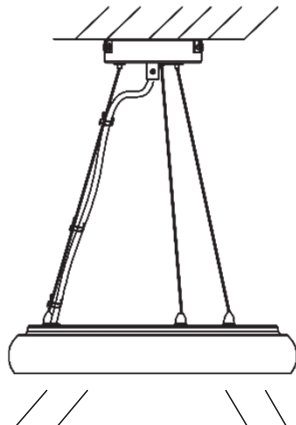

Packaging Information

Surface Mounted Ring version	SIZE(CM)	N.W./pc (KGS)	G.W.(KGS)	Q'TY(PCS)
Carton	45.5*46*50	1.6	12	6

Surface Mounted Ring version	CTNS	Q'TY(PCS)	VOLUME(CBM)
20' standard container	265	1590	28
40' standard container	530	3180	56

Surface Mounted Disc version	SIZE(CM)	N.W./pc (KGS)	G.W.(KGS)	Q'TY(PCS)
Carton	45.5*46*50	2.1	15	6

Surface Mounted Disc version	CTNS	Q'TY(PCS)	VOLUME(CBM)
20' standard container	265	1590	28
40' standard container	530	3180	56

Suspended accessories	SIZE(CM)	N.W./pc (KGS)	G.W.(KGS)	Q'TY(PCS)
Carton	45.5*46*50	1.89	13.8	6

Suspended accessories	CTNS	Q'TY(PCS)	VOLUME(CBM)
20' standard container	265	1590	28
40' standard container	530	3180	56

